



**56657-6**

## **O-Ring/Backup Ring Kit**

**FloStat® and ISARMATIC® Hydraulic Systems**



## TABLE OF CONTENTS

|   | Page |
|---|------|
| <b>INSTALLING GLAND NUTS AND PACKING NUTS</b> .....             | 3    |
| <b>FloStat® HYDRAULICS</b>                                      |      |
| Straight Blades (except HTS™).....                              | 4    |
| HTS Blades .....  | 6    |
| MVP® Blades .....   | 8    |
| MVP PLUS™ and MVP 3™ Blades.....                                | 10   |
| WIDE-OUT™ Blades.....   | 12   |
| PRODIGY™ Blades .....   | 14   |
| <b>SOLENOID ISARMATIC® HYDRAULICS FOR STRAIGHT BLADES</b> ..... | 16   |
| <b>HYDRAULIC FITTING AND HOSE INSTALLATION</b> .....            | 18   |
| <b>O-RING/BACKUP RING SIZE CHART</b> .....                      | 19   |

This kit contains O-rings and backup rings for hydraulic units used with FloStat® and ISARMATIC® hydraulic systems.

- Use the O-Ring/Backup Ring Size Chart at the end of this document to sort O-rings by size.
- This kit contains more O-rings than needed for any application.
- The small bag contains -903, -904, and -906 O-rings for the SAE O-ring plugs. See note on size chart about these O-rings.
- Use red -008 O-rings only on MVP FloStat pilot-operated check valve spools.
- Apply a light film of hydraulic fluid to all O-rings before installation.

## INSTALLING GLAND NUTS AND PACKING NUTS

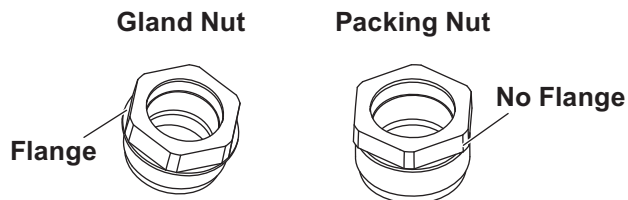

### Gland Nut Rams (Hex Flange Head on Nut)

#### Piston Locknut to Rod (Double-Acting Rams Only)

2" Rams: 100–120 ft-lb

1-1/2" Rams: 35–40 ft-lb

#### Gland Nut

**1" Single-Acting and 1-1/2" Double-Acting Rams:** 120–150 ft-lb

**All Other Rams:** 150–180 ft-lb

**Alternate Method:** Thread the nut into the coupling. Insert a feeler gauge (0.015" for 1" single-acting and 1-1/2" double-acting rams, 0.012" for all other rams) between the front surface of the cylinder tube face and the hex of the gland nut. Tighten the gland nut until it is snug against the feeler gauge. Remove the feeler gauge and tighten the gland nut an additional **1/4 turn**. This adjustment procedure will provide the torque listed above.

Undertightening may result in the nut loosening during snowplow operation.

### Packing Nut Rams (Hex Head on Nut)

#### Lift Ram Packing Nut (Single-Acting Rams Only)

Tighten the packing nut not more than 1/4 turn after you feel the packing nut contact the packing.

Overtightening affects ram operation and packing life.

FloStat® Hydraulic Unit – Straight Blades (Except HTS™)

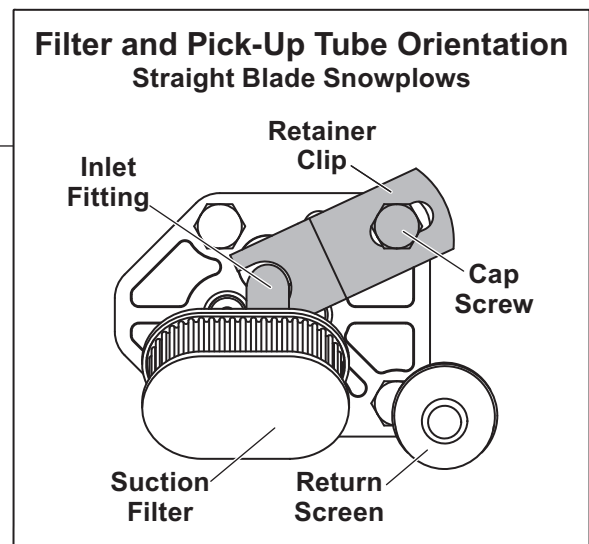
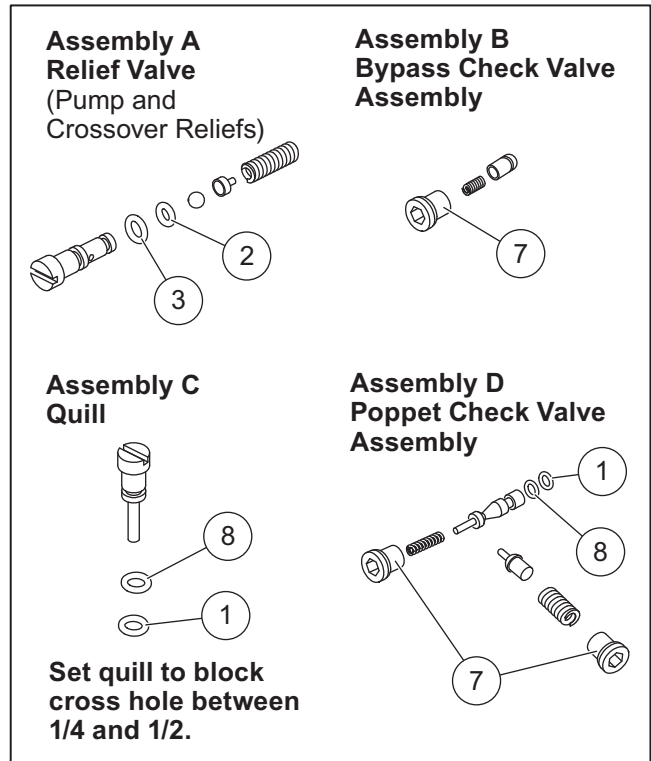
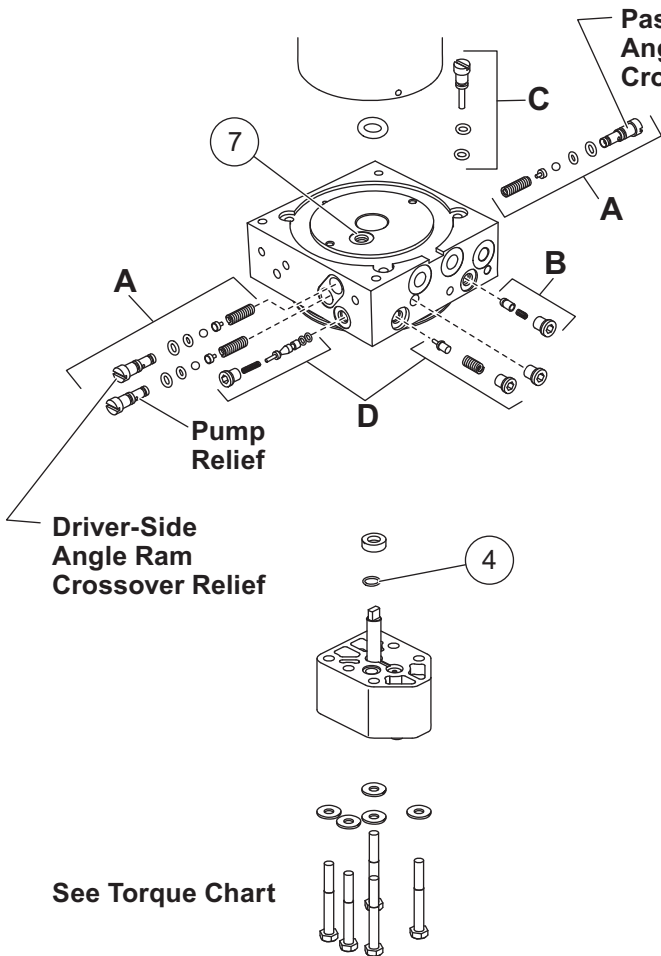

**FloStat® Hydraulic Unit – Straight Blades  
(Except HTS™)**

| Item | Part  | Qty* | Description         |
|------|-------|------|---------------------|
| 1    | 25622 | 2    | O-Ring -006         |
| 2    | 55371 | 3    | O-Ring -008 (Black) |
| 3    | 25731 | 3    | O-Ring -010         |
| 4    | 56274 | 1    | O-Ring -013         |
| 5    | 56416 | 1    | O-Ring -014         |
| 6    | 66519 | 1    | O-Ring -250         |
| 7    | 26784 | 4    | O-Ring -903         |
| 8    | 56315 | 2    | Backup Ring -006    |

\* Qty used for this application. Kit contains extra parts.

**⚠ WARNING**

**Do not stand between the vehicle and the blade or within 8 feet of a moving blade. A moving or falling blade could cause personal injury.**

Assemble the parts as shown and tighten the relief valve stems until the spring is fully compressed. Then back out the valve stem (rotate counterclockwise) the number of turns indicated in the chart below.

| Relief Valve                         | No. of Turns Out (CCW) from Fully Seated | Approx. Relief Valve Pressure (± 50 psi) |
|--------------------------------------|--|--|
| Pump Relief                          | 2-1/4 to 2-1/2                           | 2250**                                   |
| DS and PS Angle Ram Crossover Relief | 1 to 1-1/4                               | 4000                                     |

\*\* Install a tee in line with the passenger-side angle ram hydraulic hose and attach a 3000 psi gauge. Read the pressure at pump relief when holding the angle left function button. Adjust pump relief valve to obtain 2250 ± 50 psi. Relieve pressure before adjusting.

**Torque Chart – FloStat Hydraulic Unit, Straight Blades (Except HTS)**

| Location   | Fastener Size   | Torque        |
|--|---|---------------|
| Pump Cap Screws  | 5/16-18 x 2-1/2 <b>with</b> Flat Washer<br><b>or</b> 5/16-18 x 2-1/4 <b>without</b> Flat Washer | 150–160 in-lb |
| Motor Terminals (+ and –)                                    | 5/16-18 or 5/16-24 Nut  | 50–60 in-lb   |
| Motor to Manifold Cap Screws                                 | 1/4-20 x 6-1/4  | 55–65 in-lb*  |
| Reservoir Screws   | #10-24 x 5/16   | 30–35 in-lb*  |
| Solenoid Valves  | 7/8 Head Hex  | 19–21 ft-lb   |
| Coil Nuts  | 3/4 Head Hex Jam Nut  | 40–60 in-lb   |
| Valve Cover Screws   | #8-32 x 1/2   | 15–20 in-lb   |
| SAE O-Ring Plugs –3  | 1/8 or 5/32 Internal Hex  | 7–9 ft-lb     |
| Lift Frame Cross Member to Manifold<br>Cap Screw (no washer) | 3/8-16 x 1  | 180–240 in-lb |
| Manifold Mount Bolts   | 1/4-20 x 2-3/4  | 105–115 in-lb |

\* Torque with low-strength threadlocker.

FloStat® HYDRAULIC UNIT – HTS™ Blades

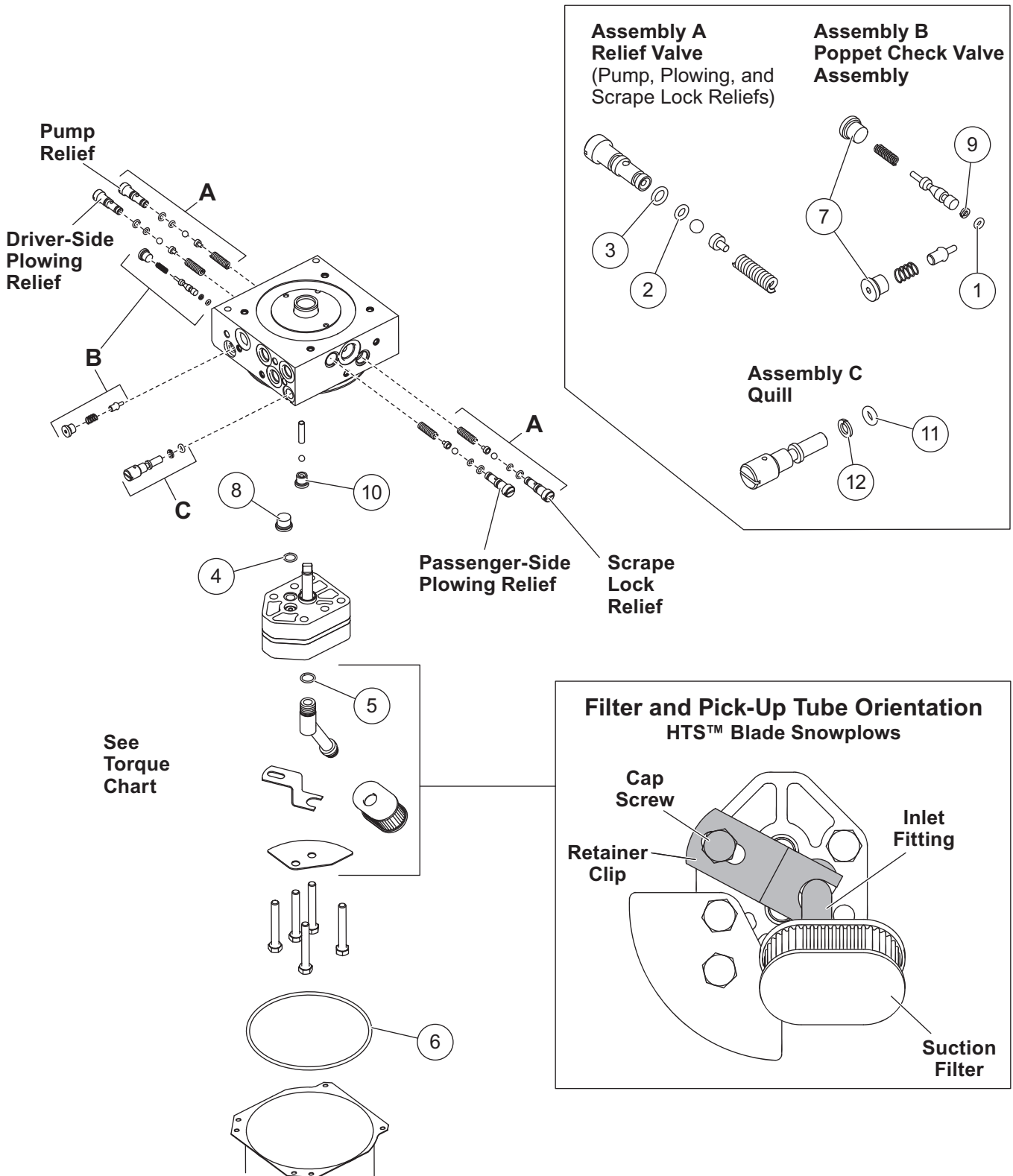

| FloStat® Hydraulic Unit – HTS™ Blades |       |      |                     |
|---------------------------------------|-------|------|---------------------|
| Item                                  | Part  | Qty* | Description         |
| 1                                     | 25622 | 1    | O-Ring -006         |
| 2                                     | 55371 | 3    | O-Ring -008 (Black) |
| 3                                     | 25731 | 3    | O-Ring -010         |
| 4                                     | 56274 | 1    | O-Ring -013         |
| 5                                     | 56416 | 1    | O-Ring -014         |
| 6                                     | 66519 | 1    | O-Ring -250         |
| 7                                     | 26784 | 4    | O-Ring -903         |
| 8                                     | 56569 | 1    | O-Ring -906         |
| 9                                     | 56315 | 1    | Backup Ring -006    |
| 10                                    | 44343 | 1    | O-Ring -904         |
| 11                                    | 48239 | 1    | O-Ring -106         |
| 12                                    | 48240 | 1    | Backup Ring -106    |

\* Qty used for this application. Kit contains extra parts.

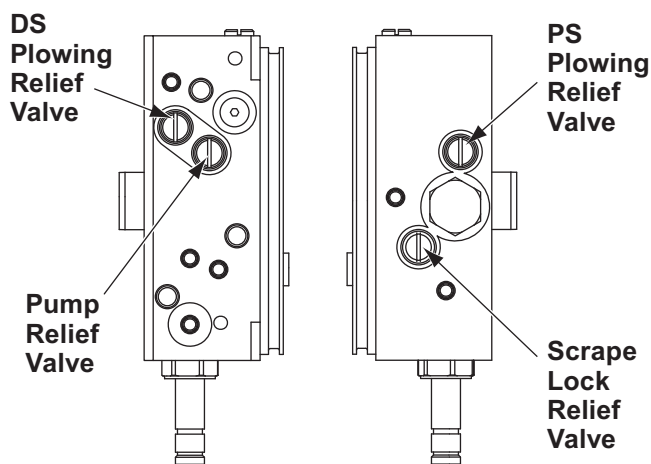

## Relief Valve Service

Apply one drop of low-strength threadlocker to all relief valve stems.

The spring for the scrape lock relief is different from the other springs and should not be interchanged.

## Plowing Relief Valve Adjustment

Screw the stem in until the spring is fully compressed, then back out 1 to 1-1/4 turns for approximately 4000 psi angle ram relief.

### **⚠ WARNING**

**Do not stand between the vehicle and the blade or within 8 feet of a moving blade. A moving or falling blade could cause personal injury.**

## Pump Relief Valve Adjustment

Attach a 3000 psi gauge in line with the passenger-side ram. Adjust relief valve C to obtain 1650 psi pump relief pressure at full angle left. Relieve pressure before adjusting.

## Scrape Lock Relief Valve Adjustment

Attach a 3000 psi gauge in line with the base end of the lift ram. Adjust relief valve D to obtain 275 psi while blade is being raised. Relieve pressure before adjusting.

## TORQUE CHART – FloStat Hydraulic Unit, HTS Blades (MUX Straight Blade w/Scrape Lock)

| Location                     | Fastener Size            | Torque        |
|------------------------------|--------------------------|---------------|
| Pump Cap Screws              | 5/16-18 x 2-1/4          | 150–160 in-lb |
| Motor Terminals (+ and –)    | M6 Nut                   | 25–35 in-lb   |
| Motor to Manifold Cap Screws | M5 x .8                  | 35–45 in-lb*  |
| Reservoir Screws             | #10-24 x 5/16            | 30–35 in-lb*  |
| Solenoid Valves              | 7/8 Hex Head             | 19–21 ft-lb   |
| Coil Nuts                    | 3/4 Hex Head Jam Nut     | 48–60 in-lb   |
| SAE O-Ring Plugs –3          | 1/8 or 5/32 Internal Hex | 7–9 ft-lb     |
| Hydraulic Unit Mount Bolts   | 3/8-16 x 1               | 22–25 ft-lb   |
| Check Valves                 | 7/8 Hex Head             | 19–21 ft-lb   |
| Motor Relay Small Terminals  | 10-32 Nut                | 15 in-lb max. |
| Motor Relay Large Terminals  | 5/16-24 Nut              | 35 in-lb max. |
| Motor Relay Mount Screws     | 1/4-20 x 5/8             | 75–85 in-lb   |
| Plow Module Mount Screws     | 1/4-20 x 5/8             | 60–70 in-lb   |

\* Torque with low-strength threadlocker

FloStat® Hydraulic Unit – MVP® Blades

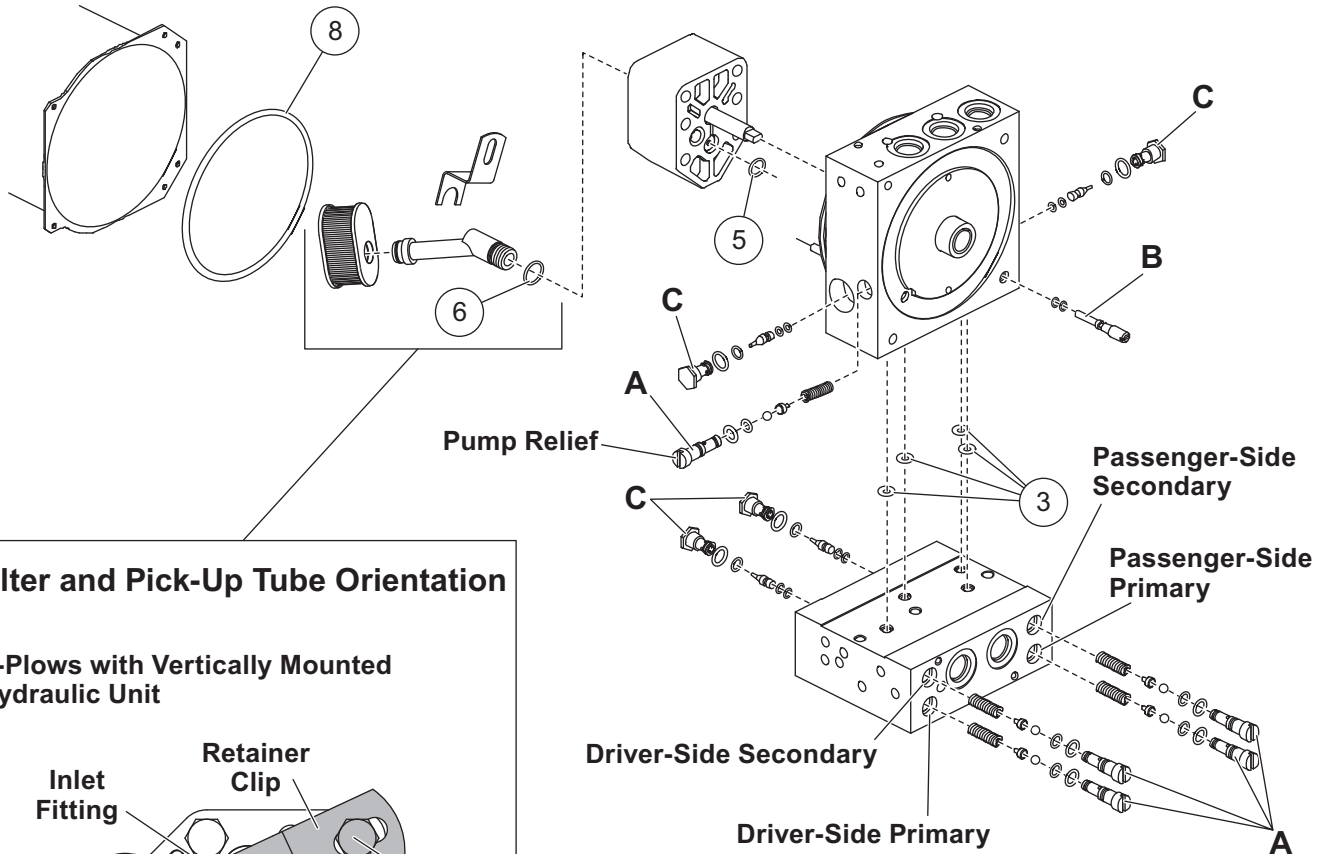

Filter and Pick-Up Tube Orientation

V-Plows with Vertically Mounted Hydraulic Unit

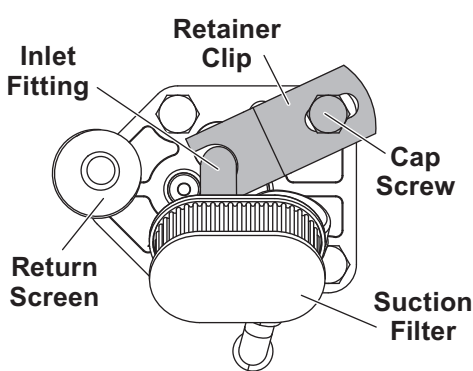

V-Plows with Horizontally Mounted Hydraulic Unit

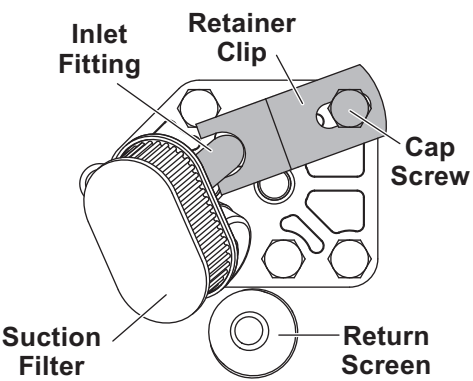

Assembly A – Relief Valve

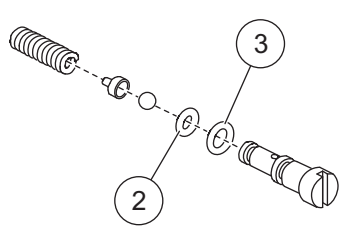

Assembly B – Quill

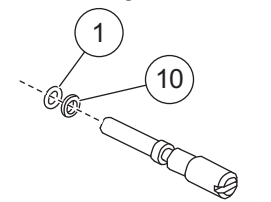

Set quill to block cross hole between 1/4 and 1/2.

Assembly C – Pilot-Operated Check Valve

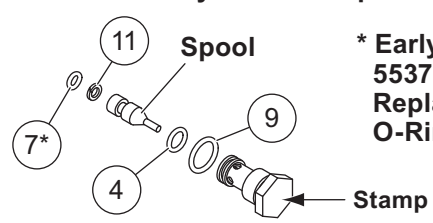

\* Early production used 55371 O-Ring -008 (Black). Replace with 56776 O-Ring -008 (Red).

| FloStat® Hydraulic Unit – MVP® Blades |       |      |   |
|---------------------------------------|-------|------|---|
| Item                                  | Part  | Qty* | Description   |
| 1                                     | 25622 | 1    | O-Ring -006   |
| 2                                     | 55371 | 5    | O-Ring -008 (Black)<br>90 durometer                 |
| 3                                     | 25731 | 9    | O-Ring -010   |
| 4                                     | 66627 | 4    | O-Ring -011 (Check valves<br>stamped V4 and lower)  |
|                                       | 25730 | 4    | O-Ring -012 (Check valves<br>stamped V5 and higher) |
| 5                                     | 56274 | 1    | O-Ring -013   |
| 6                                     | 56416 | 1    | O-Ring -014   |
| 7                                     | 56776 | 4    | O-Ring -008 (Red)<br>70 durometer                   |
| 8                                     | 66519 | 1    | O-Ring -250   |
| 9                                     | 56569 | 4    | O-Ring -906   |
| 10                                    | 56315 | 1    | Backup Ring -006                                    |
| 11                                    | 66628 | 4    | Backup Ring -008                                    |

\* Qty used for this application. Kit contains extra parts.

### ⚠ WARNING

**Do not stand between the vehicle and the blade or within 8 feet of a moving blade. A moving or falling blade could cause personal injury.**

Assemble the parts as shown and tighten the relief valve stems until the spring is fully compressed. Then back out the valve stem (rotate counterclockwise) the number of turns indicated in the chart.

| Relief Valve                            | No. of Turns Out (CCW) from Fully Seated | Approx. Relief Valve Pressure (± 50 psi) |
|---|--|--|
| Pump Relief                             | 2-1/4 to 2-3/4                           | 1750**                                   |
| DS and PS Angle<br>Ram Primary Relief   | 1-1/4 to 1-1/2***                        | 3500                                     |
| DS and PS Angle<br>Ram Secondary Relief | 1 to 1-1/4***                            | 4000                                     |

\*\* Install a tee in line with the passenger-side rod-end angle ram hydraulic hose and attach a 3000 psi gauge. Read the pressure at pump relief when holding the right retract function button. Adjust the pump relief valve to obtain 1750 ± 50 psi. Relieve pressure before adjusting.

\*\*\* Be certain the ram primary relief valve stem is backed out 1/4 turn farther than the secondary relief valve stem.

## TORQUE CHART – FloStat Hydraulic Unit, MVP Blades

| Location   | Fastener Size   | Torque        |
|--|---|---------------|
| Pump Cap Screws  | 5/16-18 x 2-1/2 <b>with</b> Flat Washer<br><b>or</b> 5/16-18 x 2-1/4 <b>without</b> Flat Washer | 150–160 in-lb |
| Motor Terminals (+ and –)                                    | 5/16-18 or 5/16-24 Nut  | 50–60 in-lb   |
| Motor to Manifold Cap Screws                                 | 1/4-20 x 6-1/4  | 55–65 in-lb*  |
| Reservoir Screws   | #10-24 x 5/16   | 30–35 in-lb*  |
| Solenoid Valves  | 7/8 Head Hex  | 19–21 ft-lb   |
| Coil Nuts  | 3/4 Head Hex Jam Nut  | 40–60 in-lb   |
| Valve Cover Screws   | #8-32 x 1/2   | 15–20 in-lb   |
| SAE O-Ring Plugs –3  | 1/8 or 5/32 Internal Hex  | 7–9 ft-lb     |
| Lift Frame Cross Member to Manifold<br>Cap Screw (no washer) | 3/8-16 x 1  | 180–240 in-lb |
| Manifold Mount Bolts   | 1/4-20 x 2-3/4  | 105–115 in-lb |
| Check Valves   | 11/16 Hex Head  | 120–144 in-lb |
| Secondary to Primary Manifolds                               | 1/4-20 x 2-1/2  | 105–115 in-lb |

\* Torque with low-strength threadlocker.

FloStat® Hydraulic Unit – MVP PLUS™ and MVP 3™ Blades

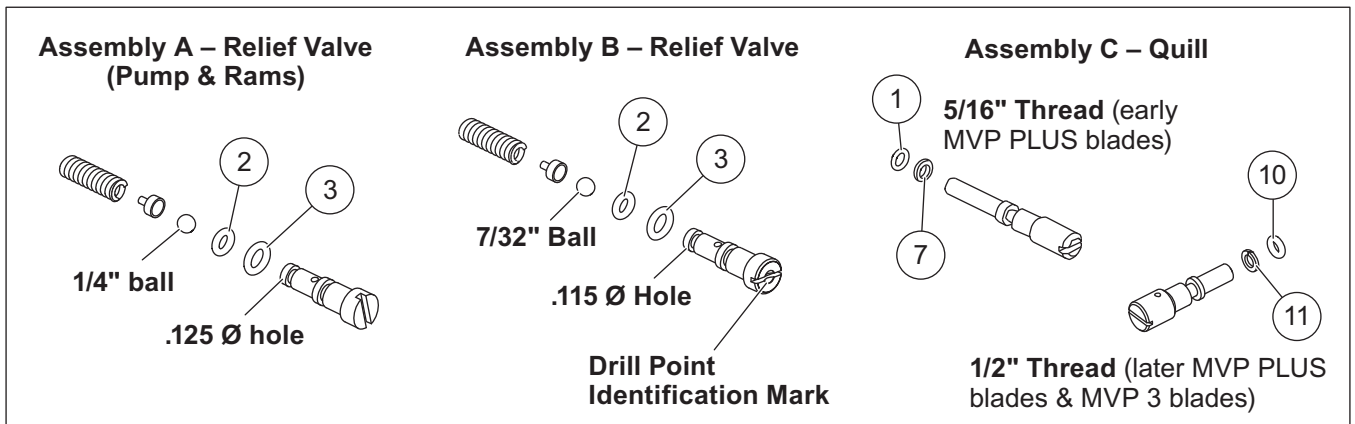
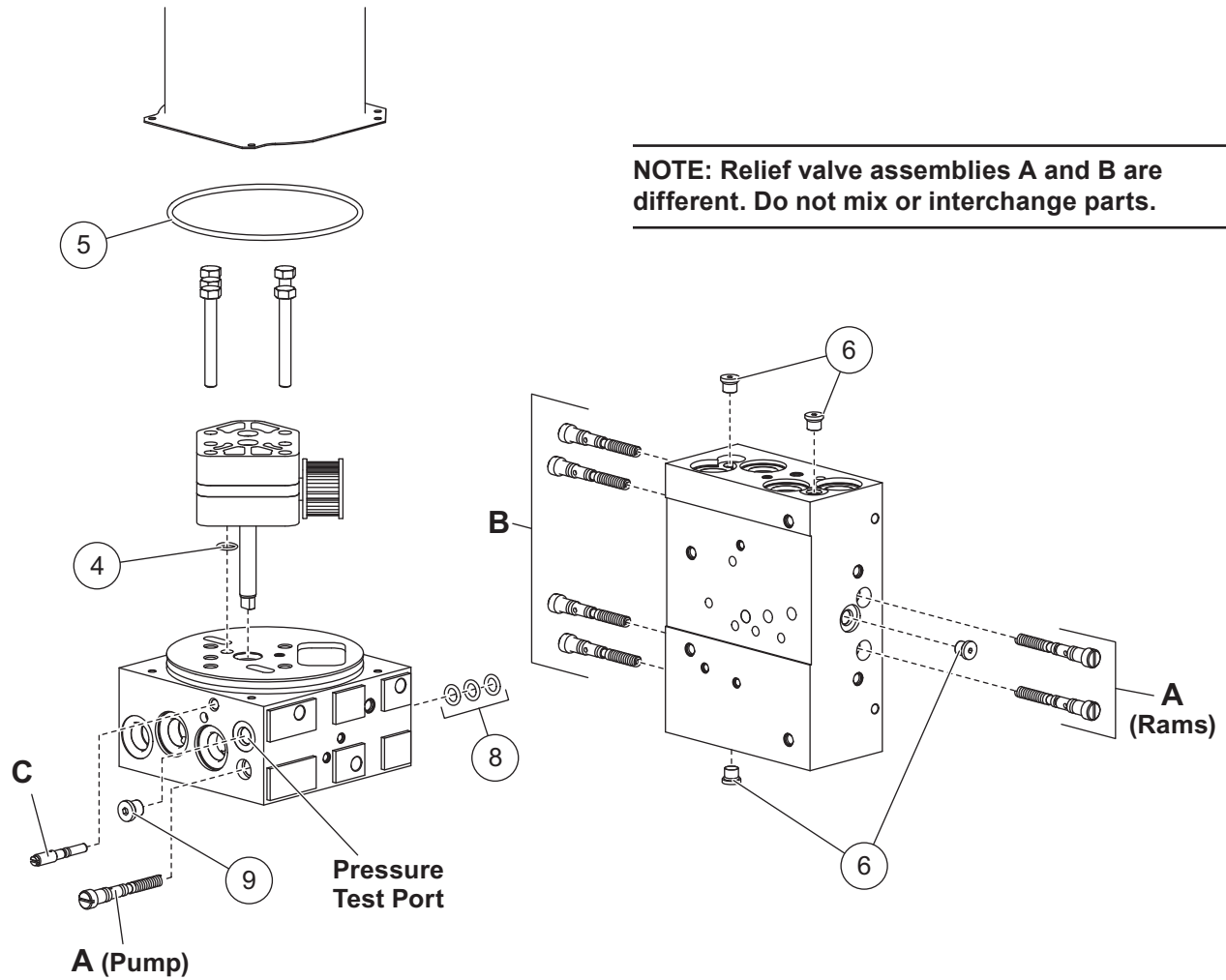

| FloStat® Hydraulic Unit – MVP PLUS™ and MVP 3™ Blades |       |      |                                     |
|---|-------|------|-------------------------------------|
| Item  | Part  | Qty* | Description                         |
| 1   | 25622 | 1    | O-Ring -006                         |
| 2   | 55371 | 7    | O-Ring -008 (Black)<br>90 durometer |
| 3   | 25731 | 7    | O-Ring -010                         |
| 4   | 56274 | 1    | O-Ring -013                         |
| 5   | 66519 | 1    | O-Ring -250                         |
| 6   | 26784 | 4    | O-Ring -903                         |
| 7   | 56315 | 1    | Backup Ring-006                     |
| 8   | 29077 | 3    | O-Ring -110                         |
| 9   | 44343 | 1    | O-Ring -904                         |
| 10  | 48239 | 1    | O-Ring -106                         |
| 11  | 48240 | 1    | Backup Ring -106                    |

\* Qty used for this application. Kit contains extra parts.

Relief valves B use a 7/32" ball, and the stem is marked with drill point in the screwdriver slot. Relief valves A and C use a 1/4" ball, and the stem is unmarked. DO NOT MIX OR INTERCHANGE PARTS.

### ⚠ WARNING

Do not stand between the vehicle and the blade or within 8 feet of a moving blade. A moving or falling blade could cause personal injury.

**Adjustment:** Screw the stem in until the spring is fully compressed, then back out the number of turns shown in the chart.

| Relief Valve | No. of Turns Out (CCW) from Fully Seated | Approx. Relief Valve Pressure (± 50 psi) |
|--------------|--|--|
| A (rams)     | 1-1/4                                    | 3700                                     |
| B            | 1-1/4                                    | 4600                                     |
| A (pump)     | 2-1/4 to 2-1/2                           | 2250**                                   |

\*\* Attach a 3000 psi gauge to the pressure test port above the valve. Read pump relief pressure when holding the right retract button. Adjust the pump relief valve to obtain 2250 ± 50 psi. Relieve pressure before adjusting.

## Torque Chart – FloStat Hydraulic Unit, MVP PLUS, and MVP 3 Blades

| Location                              | Fastener Size                  | Torque        |
|---------------------------------------|--------------------------------|---------------|
| Pump Cap Screws                       | 5/16-18 x 2-1/2                | 150–160 in-lb |
| Motor Terminals (+ and –)             | 5/16-18 Nut                    | 50–60 in-lb   |
| Motor to Manifold Cap Screws          | 1/4-20 x 6-1/4                 | 55–65 in-lb*  |
| Reservoir Screws                      | #10-24 x 5/16                  | 30–35 in-lb*  |
| Solenoid Valves                       | 7/8 Head Hex                   | 19–21 ft-lb   |
| Coil Nuts                             | 3/4 Head Hex Jam Nut           | 40–60 in-lb   |
| Cover Screws                          | 1/4-20 x 1/2 Shoulder Screw    | 60–80 in-lb   |
| SAE O-Ring Plugs –3                   | 1/8 or 5/32 Internal Hex       | 7–9 ft-lb     |
| Hydraulic Unit Mount Bolts            | 3/8-16 x 1                     | 25–33 ft-lb   |
| Check Valves                          | 7/8 Hex Head                   | 19–21 ft-lb   |
| Secondary to Primary Manifolds        | 1/4-20 x 3                     | 10–13 ft-lb   |
| Motor Relay Small Terminals           | 10-32 Nut                      | 15 in-lb max. |
| Motor Relay Large Terminals           | 5/16-24 Nut                    | 35 in-lb max. |
| Motor Relay Mount Screws              | 1/4-20 x 1/4                   | 75–85 in-lb   |
| Plow Module Mount Screws              | 1/4-20 x 5/8                   | 60–70 in-lb   |
| Pressure Test Port SAE O-Ring Plug –4 | 1/8 or 5/32 Internal Hex Screw | 10–13 ft-lb   |

\* Torque with low-strength threadlocker.

FloStat® Hydraulic Unit – WIDE-OUT™ Blades

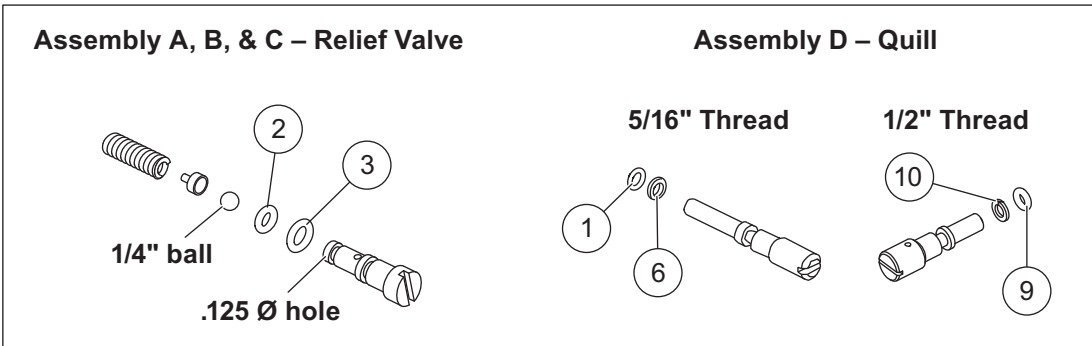
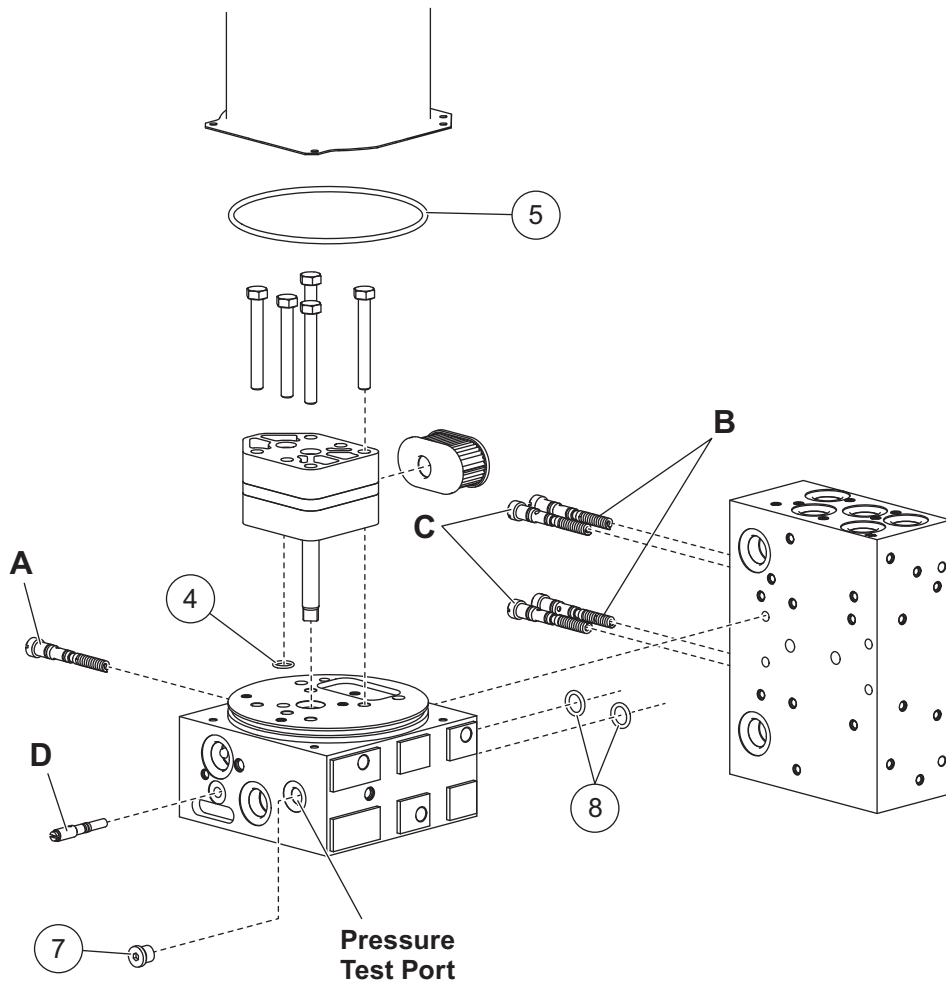

| FloStat® Hydraulic Unit – WIDE-OUT™ Blades |       |      |                                     |
|--|-------|------|-------------------------------------|
| Item                                       | Part  | Qty* | Description                         |
| 1  | 25622 | 1    | O-Ring -006                         |
| 2  | 55371 | 5    | O-Ring -008 (Black)<br>90 durometer |
| 3  | 25731 | 5    | O-Ring -010                         |
| 4  | 56274 | 1    | O-Ring -013                         |
| 5  | 66519 | 1    | O-Ring -250                         |
| 6  | 56315 | 1    | Backup Ring -006                    |
| 7  | 44343 | 1    | O-Ring -904                         |
| 8  | 44905 | 2    | O-Ring -112 (Spotted)               |
| 9  | 48239 | 1    | O-Ring -106                         |
| 10   | 48240 | 1    | Backup Ring -106                    |

\* Qty used for this application. Kit contains extra parts.

### ⚠ WARNING

**Do not stand between the vehicle and the blade or within 8 feet of a moving blade. A moving or falling blade could cause personal injury.**

Assemble the parts as shown and tighten the relief valve stems until the spring is fully compressed. Then back out the valve stem (rotate counterclockwise) the number of turns indicated in the chart below.

| Relief Valve | No. of Turns Out (CCW) from Fully Seated | Approx. Relief Valve Pressure (± 50 psi) |
|--------------|--|--|
| A            | 2-1/4 to 2-1/2                           | 2250**                                   |
| B            | 2  | 2200                                     |
| C            | 1-3/4                                    | 2400                                     |

\*\* Attach a 3000 psi gauge to the pressure test port on the face with coils. Read pump relief pressure when holding the angle right button. Adjust the pump relief valve located on port side to obtain 2250 ± 50 psi. Relieve pressure before adjusting.

## TORQUE CHART – FloStat Hydraulic Unit, WIDE-OUT Blades

| Location                              | Fastener Size                  | Torque        |
|---------------------------------------|--------------------------------|---------------|
| Pump Cap Screws                       | 5/16-18 x 2-1/2                | 150–160 in-lb |
| Motor Terminals (+ and –)             | 5/16-18 Nut                    | 50–60 in-lb   |
| Motor to Manifold Cap Screws          | 1/4-20 x 6-1/4                 | 55–65 in-lb*  |
| Reservoir Screws                      | #10-24 x 5/16                  | 30–35 in-lb*  |
| Solenoid Valves                       | 7/8 Head Hex                   | 19–21 ft-lb   |
| Coil Nuts                             | 3/4 Head Hex Jam Nut           | 40–60 in-lb   |
| Cover Screws                          | 1/4-20 x 1/2 Shoulder Screw    | 60–80 in-lb   |
| SAE O-Ring Plugs –3                   | 1/8 or 5/32 Internal Hex       | 7–9 ft-lb     |
| Hydraulic Unit Mount Bolts            | 3/8-16 x 1                     | 25–33 ft-lb   |
| Check & PO Check Valves               | 7/8 Hex Head                   | 19–21 ft-lb   |
| Secondary to Primary Manifolds        | 1/4-20 x 3                     | 10–13 ft-lb   |
| Motor Relay Small Terminals           | 10-32 Nut                      | 15 in-lb max. |
| Motor Relay Large Terminals           | 5/16-24 Nut                    | 35 in-lb max. |
| Motor Relay Mount Screws              | 1/4-20 x 1/4                   | 75–85 in-lb   |
| Plow Module Mount Screws              | 1/4-20 x 5/8                   | 60–70 in-lb   |
| Pressure Test Port SAE O-Ring Plug –4 | 1/8 or 5/32 Internal Hex Screw | 10–13 ft-lb   |

\* Torque with low-strength threadlocker.

FloStat® Hydraulic Unit – PRODIGY™ Blades

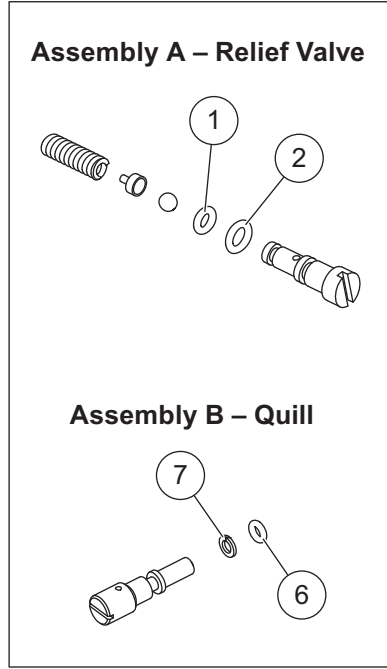
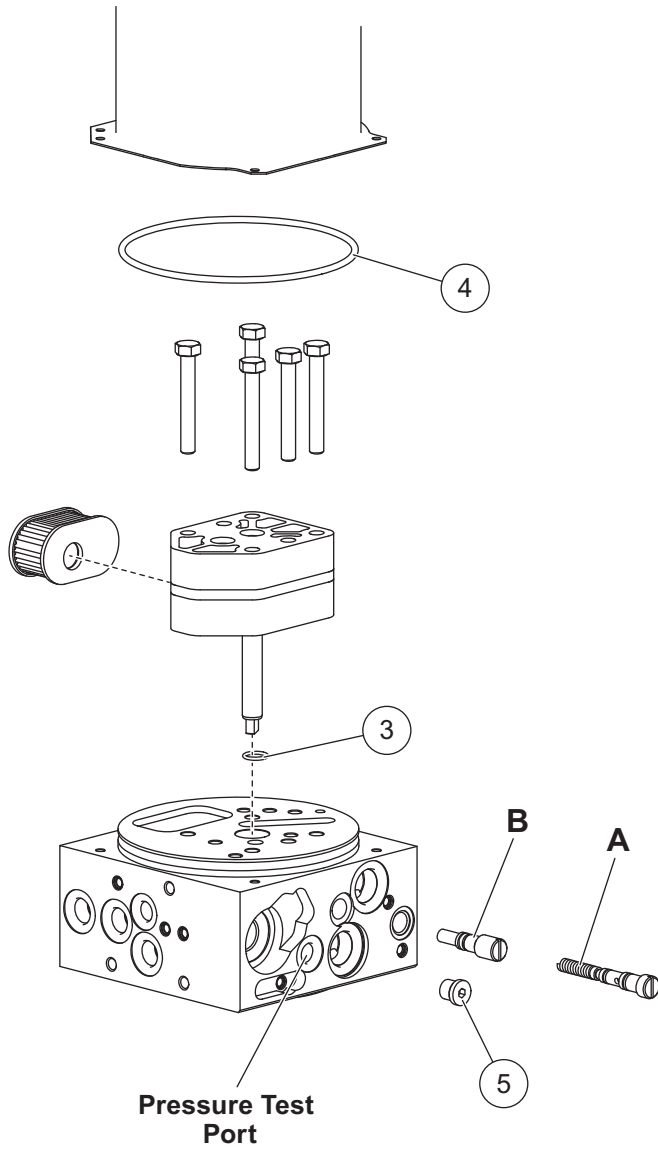

| FloStat® Hydraulic Unit – PRODIGY™ Blades |       |      |                                     |
|---|-------|------|-------------------------------------|
| Item                                      | Part  | Qty* | Description                         |
| 1   | 55371 | 5    | O-Ring -008 (Black)<br>90 durometer |
| 2   | 25731 | 5    | O-Ring -010                         |
| 3   | 56274 | 1    | O-Ring -013                         |
| 4   | 66519 | 1    | O-Ring -250                         |
| 5   | 44343 | 1    | O-Ring -904                         |
| 6   | 48239 | 1    | O-Ring -106                         |
| 7   | 48240 | 1    | Backup Ring -106                    |

\* Qty used for this application. Kit contains extra parts.

### ⚠ WARNING

**Do not stand between the vehicle and the blade or within 8 feet of a moving blade. A moving or falling blade could cause personal injury.**

Assemble the parts as shown and tighten the relief valve stem until the spring is fully compressed. Then back out the valve stem (rotate counterclockwise) the number of turns indicated in the chart below.

| Relief Valve | No. of Turns Out (CCW) from Fully Seated | Approx. Relief Valve Pressure (± 50 psi) |
|--------------|--|--|
| A            | 2-1/4 to 2-1/2                           | 2250**                                   |

\*\* Attach a 3000 psi gauge to the pressure test port on the face with coils. Read pump relief pressure when holding the angle right button. Adjust the pump relief valve to obtain 2250 ± 50 psi. Relieve pressure before adjusting.

## TORQUE CHART – FloStat Hydraulic Unit, PRODIGY Blades

| Location                              | Fastener Size                  | Torque        |
|---------------------------------------|--------------------------------|---------------|
| Pump Cap Screws                       | 5/16-18 x 2-1/4                | 150–160 in-lb |
| Motor Terminals (+ and –)             | 5/16-18 Nut                    | 50–60 in-lb   |
| Motor to Manifold Cap Screws          | 1/4-20 x 6-1/4                 | 55–65 in-lb*  |
| Reservoir Screws                      | #10-24 x 5/16                  | 30–35 in-lb*  |
| Solenoid Valves and Relief Valve      | 7/8 Head Hex                   | 19–21 ft-lb   |
| Coil Nuts                             | 3/4 Head Hex Jam Nut           | 40–60 in-lb   |
| Cover Screws                          | 1/4-20 x 1/2 Shoulder Screw    | 60–80 in-lb   |
| Pressure Test Port SAE O-Ring Plug –4 | 1/8 or 5/32 Internal Hex       | 10–13 ft-lb   |
| Hydraulic Unit Mount Bolts            | 3/8-16 x 1                     | 25–33 ft-lb   |
| Counterbalance Valves                 | 1 Hex Head                     | 23–25 ft-lb   |
| Secondary to Primary Manifolds        | 1/4-20 x 3                     | 10–13 ft-lb   |
| Motor Relay Small Terminals           | 10-32 Nut                      | 15 in-lb max. |
| Motor Relay Large Terminals           | 5/16-24 Nut                    | 35 in-lb max. |
| Motor Relay Mount Screws              | 1/4-20 x 1/4                   | 75–85 in-lb   |
| Plow Module Mount Screws              | 1/4-20 x 5/8                   | 60–70 in-lb   |
| Pressure Test Port SAE O-Ring Plug –4 | 1/8 or 5/32 Internal Hex Screw | 10–13 ft-lb   |

\* Torque with low-strength threadlocker.

Solenoid ISARMATIC® Hydraulic Unit

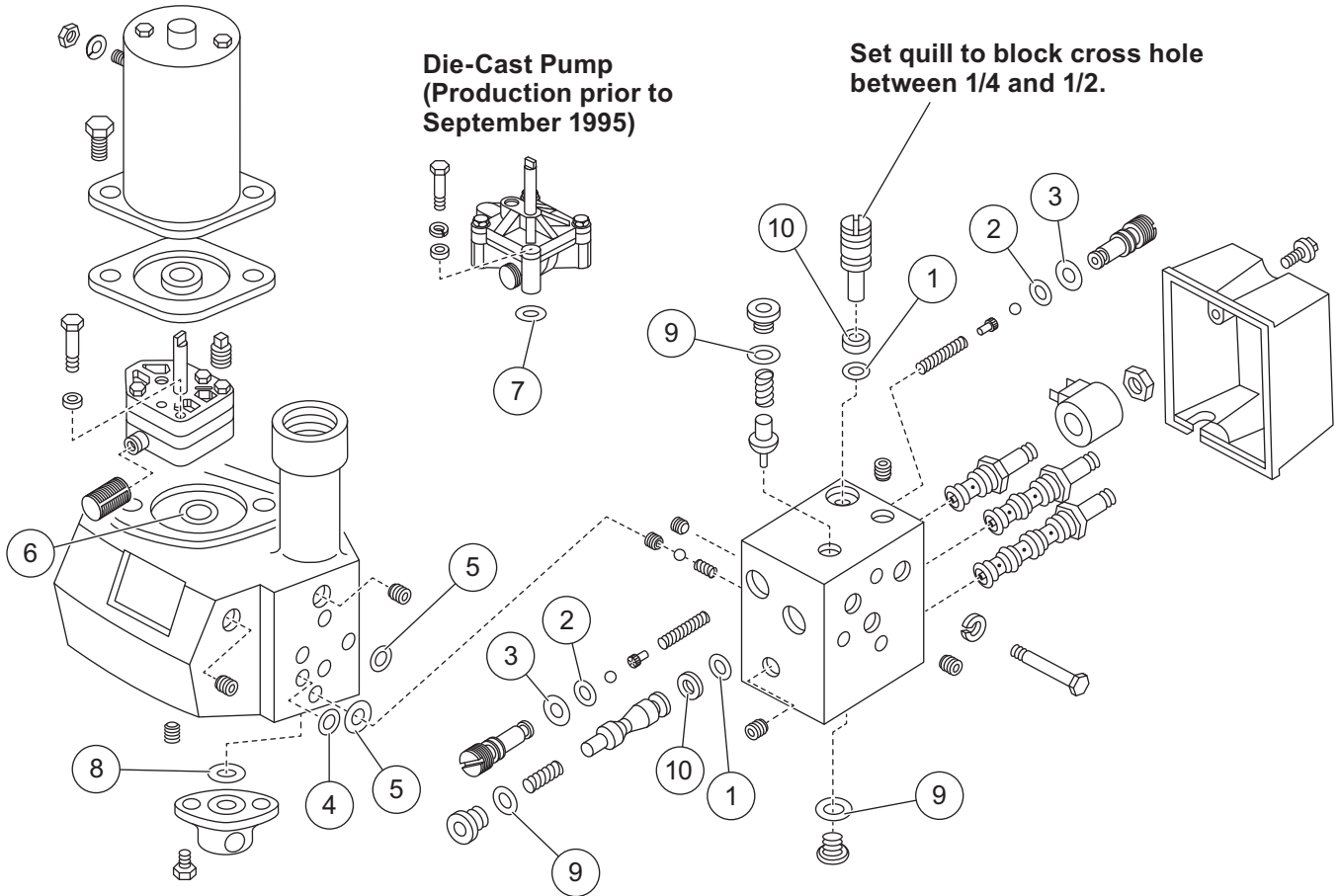

| Item | Part  | Qty* | Description         |
|------|-------|------|---------------------|
| 1    | 25622 | 2    | O-Ring -006         |
| 2    | 55371 | 2    | O-Ring -008 (black) |
| 3    | 25731 | 2    | O-Ring -010         |
| 5    | 25730 | 2    | O-Ring -012         |
| 6    | 56274 | 1    | O-Ring -013         |
| 7    | 56416 | 1    | O-Ring -014         |
| 8    | 5821  | 1    | O-Ring -115         |
| 9    | 5823  | 1    | O-Ring -216         |
| 12   | 26784 | 3    | O-Ring -903         |
| 14   | 56315 | 2    | Backup -006         |

\* Qty used for this application. Kit contains extra parts. See Torque Chart on following page.

Assemble the parts as shown and tighten the relief (cushion) valve stems until the spring is fully compressed, then back out the valve stem (rotate counterclockwise) the number of turns indicated in the chart.

| Hydra-Turn®<br>Angle Ram<br>(Diameter x<br>Stroke) | No. of Turns<br>Out (CCW)<br>from Fully<br>Seated | Approximate<br>Relief (Cushion)<br>Valve Pressure<br>(± 50 psi) |
|--|---|---|
| 1-1/2" x 6"  | 1-3/4   | 2500  |
| 1-1/2" x 12"                                       | 1-3/8   | 3500  |
| 2" x 16"   | 1-3/8   | 3500  |

---

**TORQUE CHART – Solenoid ISARMATIC® Hydraulic Units (Straight Blades Only)**

| Location                         | Fastener Size  | Torque        |
|----------------------------------|--|---------------|
| Base Lug                         | 5/16-18 x 1-1/4  | 180–215 in-lb |
| Pump                             | 5/16-18 x 2-1/4 (die-cast pump only)<br>or 5/16-18 x 2-1/2 | 175–185 in-lb |
| Front or Rear Motor              | 7/16-14 x 1-1/4  | 180–240 in-lb |
| Rear Motor                       | 7/16-14 x 1-1/2  | 180–240 in-lb |
| Valve Manifold                   | 1/4-20 x 3-1/4   | 50–55 in-lb   |
| Motor Terminals (+ and –)        | 5/16-24 Nut  | 50–60 in-lb   |
| Cable Ground Bolt to Motor Frame | 5/16-18 x 1/2  | 175–185 in-lb |
| Solenoid Valves                  | 7/8 Head Hex   | 19–21 ft-lb   |
| Coil Nuts                        | 3/4 Head Hex Jam Nut                                       | 48–50 in-lb   |
| Valve Cover Screws               | #8-32 x 1/2  | 15–20 in-lb   |
| SAE O-Ring Plugs                 | 1/8 or 5/32 Internal Hex                                   | 55–65 in-lb   |

**HYDRAULIC HOSE AND FITTING  
INSTALLATION**

**NOTE: Overtightening JIC hose fitting ends will result in a fractured fitting.**

**DO NOT** use any type of sealant or tape on the fittings or hoses. This could damage product.

Always use two wrenches to ensure proper tightening of fittings and hoses.

**SAE O-Ring Style**

**Fittings**

1. Turn the jam nut on the fitting as far back as possible.
2. Lubricate the O-ring with clean hydraulic fluid.
3. Screw the fitting into the port by hand until the washer contacts the port face and the shoulder of the jam nut threads.
4. Unscrew the fitting to proper position, no more than one full turn.
5. Using two wrenches, hold the fitting body in position and tighten the jam nut until the washer again contacts the port face. Then tighten an additional 1/8 to 1/4 turn to lock the fitting in place. Final torque on the jam nut should be approximately 20 ft-lb.

**Hydraulic Hoses**

1. Screw the flare nut onto the fitting flare and hand tighten.
2. Align the hose so there are no twists or sharp bends.
3. Using two wrenches, hold the hose in position and tighten the flare nut 1/8 to 1/4 turn beyond hand tight. Final torque on the flare nut should be approximately 20 ft-lb.

**NPTF Pipe Thread Style**

1. Screw the fitting into the female pipe port to the finger-tight position.
2. Wrench tighten the fitting to the appropriate turns from finger tight (TFFT) shown in the chart below, stopping at the position where the joining tube can be attached.

Avoid overtightening and then backing out the fitting to make the connection, as this will likely result in a leaking or weeping connection.

| Pipe Thread Size (NPTF) | TFFT       |
|-------------------------|------------|
| 1/8-27                  | 2 to 2-1/2 |
| 1/4-18                  | 1-1/2 to 2 |
| 3/8-18                  | 2 to 2-1/2 |
| 1/2-14                  | 2 to 2-1/2 |
| 3/4-14 & larger         | 1-1/2 to 2 |

# O-Ring/Backup Ring Size Chart

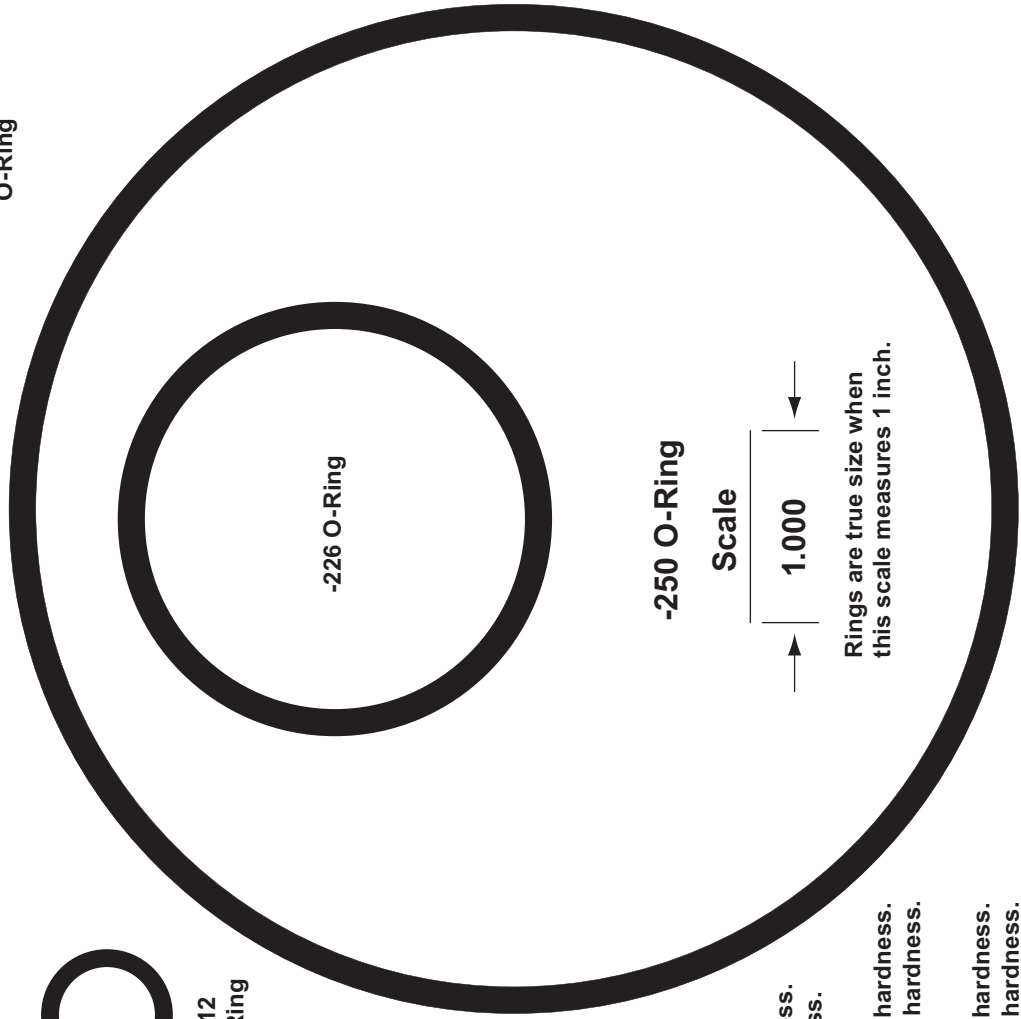

- \* -011 & -903 both have .301" ID diameter.
- 011 has .070" dia. cross section & 70 durometer hardness.
- 903 has .064 dia. cross section & 90 durometer hardness.
- \*\* -014 & -906 are similar in size.
- 014 has .489 ID, .070 dia. cross section & 70 durometer hardness.
- 906 has .468 ID, .078 dia. cross section & 90 durometer hardness.
- \*\*\* -012 & -904 are similar in size.
- 012 has .364 ID, .070 dia. cross section & 70 durometer hardness.
- 904 has .351 ID, .072 dia. cross section & 90 durometer hardness.

Copyright © 2018 Douglas Dynamics, LLC. All rights reserved. This material may not be reproduced or copied, in whole or in part, in any printed, mechanical, electronic, film, or other distribution and storage media, without the written consent of Western Products. Authorization to photocopy items for internal or personal use by Western Products outlets or snowplow owner is granted.

Western Products reserves the right under its product improvement policy to change construction or design details and furnish equipment when so altered without reference to illustrations or specifications used. Western Products or the vehicle manufacturer may require or recommend optional equipment for snow removal. Do not exceed vehicle ratings with a snowplow. Western Products offers a limited warranty for all snowplows and accessories. See separately printed page for this important information. The following are registered (®) or unregistered (™) trademarks of Douglas Dynamics, LLC: FloStat®, HTS™, Hydra-Turn®, ISARMATIC®, MVP®, MVP 3™, MVP PLUS™, PRODIGY™, UltraMount® 2, WIDE-OUT™.

**Printed in U.S.A.**

---